

# 1106A-70TAG2

# 1100

153.5 kWm (Gross) @ 1500 rpm

## Electropak

Series

### Basic technical data

Number of cylinders	6
Cylinder arrangement	Inline
Cycle	4 stroke
Induction system	Turbocharged and air charge cooled
Combustion system	Direct injection diesel
Compression ratio	18.2 : 1
Bore	105 mm
Stroke	135 mm
Cubic capacity	7.01 litres
Direction of rotation	Anticlockwise when viewed from flywheel
Firing order	1, 5, 3, 6, 2, 4
Estimated total weight (dry)	743 kg
Estimated total weight (wet)	777 kg

### Overall dimensions (Electropak)

Height	1092 mm
Length (air cleaner fitted)	1706 mm
Width	756 mm

### Moments of inertia

Engine rotational components	0.27 kgm <sup>2</sup>
Flywheel	1.2 kgm <sup>2</sup>

### Centre of gravity, Electropak

Forward from rear of block (wet)	476 mm
Above crankshaft centre line (wet)	176 mm
Offset to RHS of crankshaft centre line (wet)	16 mm

### Performance

Speed variation at constant load	± 0.75%
Cyclic irregularity at standby power	0.028
All ratings within	± 5%

**Note:** All data based on operation to ISO 3046-1:2002 standard reference conditions.

### Sound level

Sound power level for standby power @1500 rpm	109.82 dB(A)
---	--------------

### Test conditions

Air temperature	25°C
Barometric pressure	100 kPa
Relative humidity	31.5%
Air inlet restriction at maximum power	3 kPa (maximum)
Exhaust back pressure at maximum power	6 kPa (maximum)
Fuel temperature	40°C

**Note:** If the engine is to operate in ambient conditions other than those of the test conditions, suitable adjustments must be made for these changes. For full details, contact Perkins Technical Service Department.

## General installation

General Installation	Units	Prime	Standby
Gross engine power	kW	139.5	153.5
Gross BMEP	kPa	1552.1	1701.6
Mean piston speed	metres/s	6.8	
ElectropaK nett engine power	kW	131.0	144.1
Engine coolant flow (against 35 kPa restriction)	litres/min	142	
Combustion air flow (at STP)	m <sup>3</sup> /min	10.2	10.67
Exhaust gas flow (maximum)	m <sup>3</sup> /min	23.78	25.53
Exhaust gas temperature (maximum) in manifold (after turbocharger)	°C	484	
Nett engine thermal efficiency	%	39.7	39.7
Typical genset electrical output (0.8pf 25°C)	kWe	120	132
	kVA	150	165
Regenerative power (estimated)	kW	6.7	
Assumed alternator efficiency	%	91.6	
Expansion tank volume	Litre	Not required	
Charge air at turbo exit temperature (before charge cooler)	°C	137.9	149.8
Manifold charge air temperature (after charge cooler)	°C	55	
Engine air flow	kg/min	5.635	5.97
Induction manifold pressure	kPa	129.09	147.17
Maximum total pressure drop including pipes	kPa	3	

## Rating definitions

### Prime power

Unlimited hours usage, with an average load factor of 80% over each 24 hour period. A 10% overload is available for 1 hour in every 12 hours operation.

### Standby power

Limited to 500 hours annual usage, with an average load factor of 80% of the published standby power rating over each 24 hour period. Up to 300 hours of annual usage may be run continuously. No overload is permitted on standby power.

## Energy balance

Designation	Units	Prime	Standby
Heat in fuel	kW	330.2	363.1
Power to cooling fan	kW	5.0	
Power to coolant and lubricating oil	kW	69.1	75.7
Power to exhaust	kW	96.6	105.6
Energy to charge coolers	kW	17.5	20.5
Power to radiation	kW	11	12.2

## Cooling system

### Cooling pack

Overall weight (wet)	90 kg
Overall face area	494,040 mm <sup>2</sup>
Width	716 mm
Height	690 mm

### Radiator

Face area	303,600 mm <sup>2</sup>
Number of rows and materials	4 rows, Aluminium
Matrix density and material	11.3 fins per inch, Aluminium
Width of matrix	440 mm
Height of matrix	690 mm
Pressure cap setting (minimum)	110 kPa

### Charge cooler

Face area	151,800 mm <sup>2</sup>
Number of rows and materials	2 rows, Aluminium
Matrix density and material	10 fins per inch, Aluminium
Width of matrix	220 mm
Height of matrix	690 mm

### Fan

Diameter	635 mm
Drive ratio	1.25:1
Number of blades	7
Material	Nylon
Type	Pusher
Air flow @ 1500 rpm	222 m <sup>3</sup> /min
Power @ 1500 rpm	4.5 kW

### Coolant

Total system capacity	20.5 litres
System drawdown capacity	10%
Engine capacity	9.5 litres
Maximum top tank temperature	110°C
Temperature rise across engine (maximum rating dependent)	6°C - 12°C
Maximum permissible external system resistance	35 kPa
Thermostat operation range	82°C to 93°C
Shutdown switch setting	118°C
Coolant pump method of drive	Gear
Recommended coolant immersion heater rating (minimum)	0.75 kW
Recommended coolant	BS6580 - 1992, ASTM D3306 and ELC coolants to 1E1966

### Duct allowance

Maximum additional restriction (duct allowance to cooling airflow and resultant minimum air flow) - Standby power

Description	rpm	kPa	m <sup>3</sup> /min
Duct allowance with inhibited coolant at 53°C			
Minimum air flow	1500	0	164
Duct allowance with inhibited coolant at 46°C			
Minimum air flow	1500	0.12	134
Duct allowance with inhibited coolant at 46°C			
Minimum air flow	1500	0.2	115

## Electrical system

Alternator	8SI
Alternator voltage	12 volts
Alternator output	65 amps
Starter	AZF
Starter motor voltage	12 volts
Starter motor power	4.2 kW
Number of teeth on the flywheel	126
Pull-in and hold-in current of starter motor solenoid @ 25°C maximum <sup>(1)</sup>	12 volts 68 amps
Hold-in current of starter motor solenoid @ 25°C maximum <sup>(1)</sup>	12 volts 20 amps
Engine stop method	Solenoid

<sup>1</sup> All leads to rated at 10 amps minimum

### Cold start recommendations

Minimum required cranking speed over TDC 60 rpm

	5 to -10°C	-10 to -20°C	-20 to -25°C
Oil	15W40	10W40	5W40
Starter	AZF		
Battery	2 x 1200 CCA		
Cranking current	960		
Aids	None	Glowplugs	
Minimum mean cranking speed	130 rpm	100 rpm	100 rpm

**Note:** Battery capacity is defined by the 20 hour rate.

**Note:** If a change to a low viscosity oil is made, the cranking torque necessary at low ambient temperatures is much reduced. The starting equipment has been selected to take advantage of this. It is important to change to the appropriate multigrade oil in anticipation of operating in low ambient temperatures.

## Exhaust system

Maximum back pressure - 1500 rpm	6.0 kPa
Exhaust outlet, internal diameter	72 mm

## Fuel system

### Injection components

Injector ..... Mechanical  
 Fuel pump..... DP210G

### Fuel priming

Priming pump type ..... Manual  
 Maximum priming time..... 90 seconds

### Fuel feed

Maximum fuel flow ..... 3 litres/min  
 Maximum suction head at engine fuel pump inlet..... 50 kPa  
 Maximum static pressure head ..... 50 kPa  
 Fuel temperature at engine fuel pump inlet..... 85°C  
 Tolerance on fuel consumption ..... ± 5%

### Fuel specification

Fuel standard..... Various (contact Perkins Technical Department)

### Fuel consumption

Load	Type of operation and application	
	g/kWh	litres/hr
110% Prime power	201.1	36.1
Prime power	203.3	33.4
75% Prime power	199.7	24.7
50% Prime power	197.9	16.4
25% Prime power	221.1	9.1

## Induction system

### Maximum air intake restriction

Clean filter ..... 3 kPa  
 Dirty filter..... 5 kPa  
 Air filter type..... Paper element

## Lubrication system

Maximum total system oil capacity ..... 18.0 litres  
 Minimum oil capacity in sump ..... 12.5 litres  
 Maximum oil capacity in sump ..... 16.1 litres  
 Maximum engine operating angles -  
 Front up, front down, right side, left side..... 25°  
 Sump drain plug tapping size..... 3/4 - 16 UNF  
 Shutdown switch setting (where fitted)

### Lubricating oil

Relief valve opening pressure ..... 460 kPa  
 Pressure at maximum speed ..... 520 kPa  
 Maximum continuous oil temperature (in rail)..... 125°C  
 Oil consumption at full load (% of fuel) ..... < 0.1

## Recommended SAE viscosity

A multigrade oil must be used which conforms to API CH4 or CI4  
 ACEA E5 must be used, see illustration below:

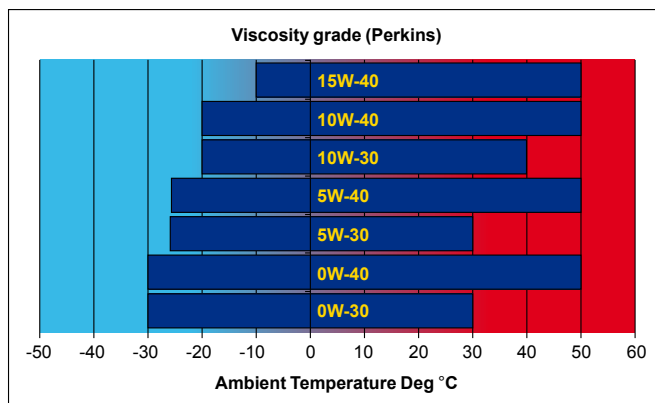

## Mountings

Maximum static bending moment at rear face of block..... 1130 Nm  
 Maximum permissible overhung load  
 on the flywheel..... Calculated on request  
 Maximum bending moment at rear of flywheel housing.....  
 ..... ± 3000 in Shock Nm

## Load acceptance

The data below complies with the requirements of classification 3 and 4  
 of ISO 8528-12 and G2 operating limits stated in ISO 8528-5.

**Initial load application:** When engine reaches rated speed  
 (15 seconds maximum after engine starts to crank).

Description	Units	
% of prime power	%	70
Load	kWe	93
Transient frequency deviation	%	< 10
Frequency recovery time	Seconds	1.4

## Noise data

### Noise levels

Position	Noise power level [dB(A)]	
	Prime power	Standby power
1	108.07	108.70
2	105.73	106.32
3	105.26	105.92
4	104.18	104.82
5	109.15	109.82
6	105.73	106.58

Noise reference level 65 dB(A)

1/3 octave analysis: TBC

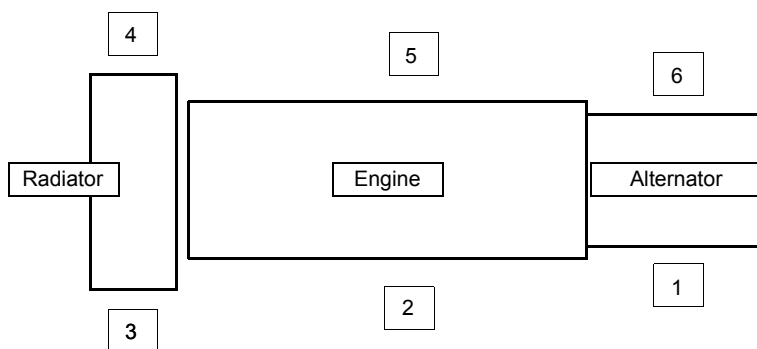

## 1106A-70TAG2 - Left side view

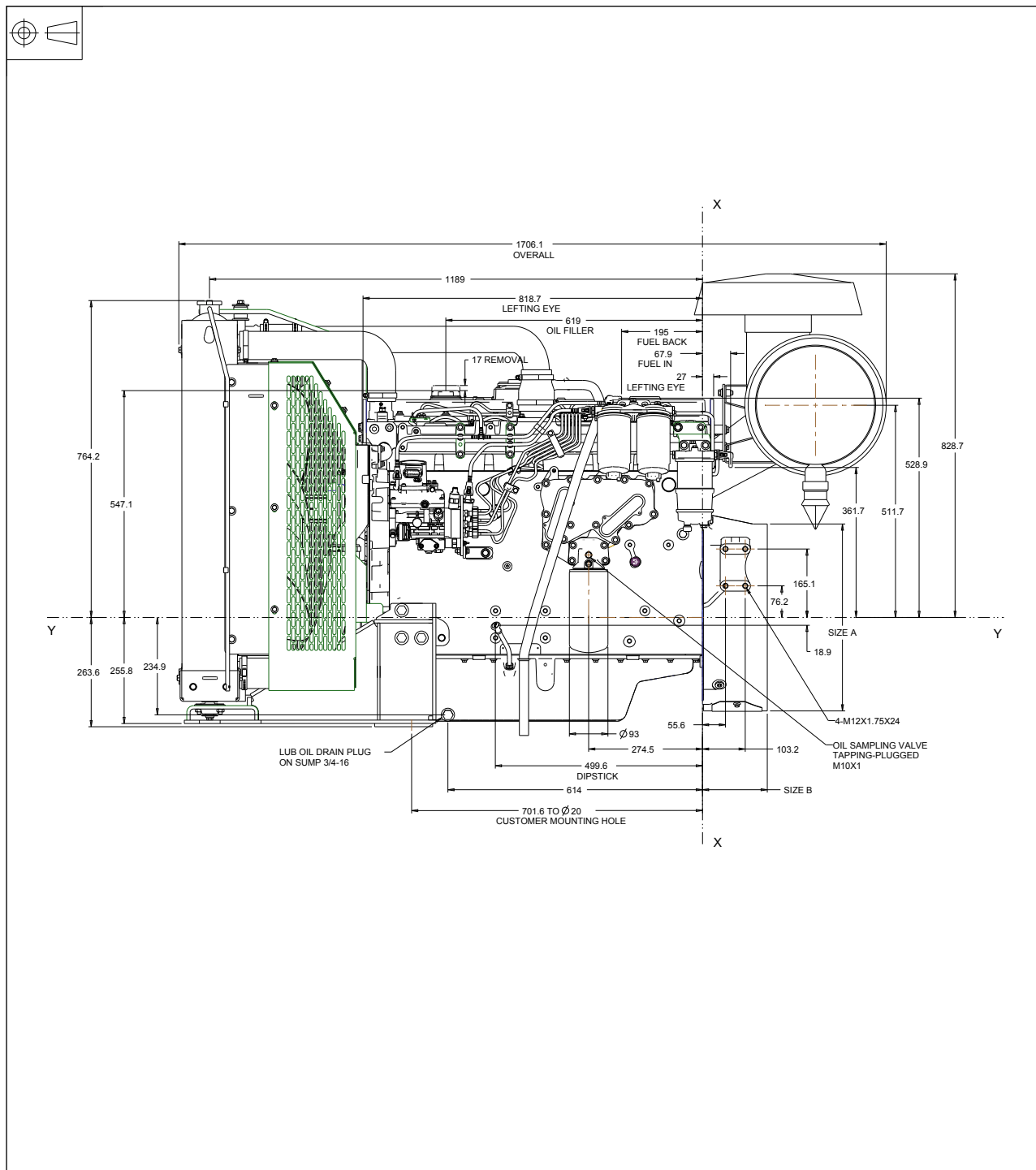

## Flywheel and housing options

Option	Part	Size A	Size B	Description
1	C0001 & D0004	ø 450.9	153.37	The type is SAE 3 Use on TAG 2 & 4
2	C0074 & D0090	ø 489	134.6	The type is SAE 2 Use on TAG 3 & 4

# 1106A-70TAG2 - Front view

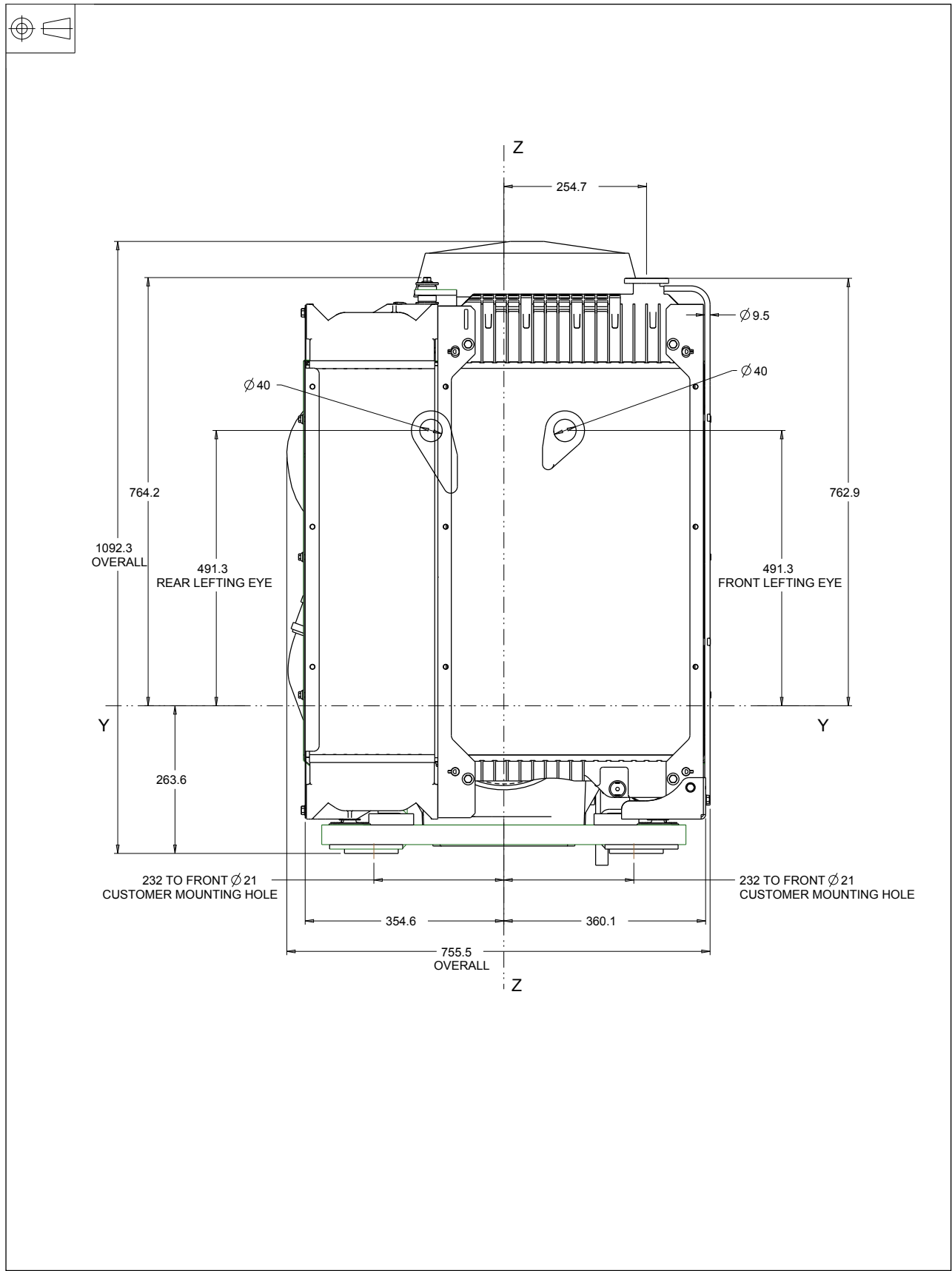

# 1106A-70TAG2 - Right side view

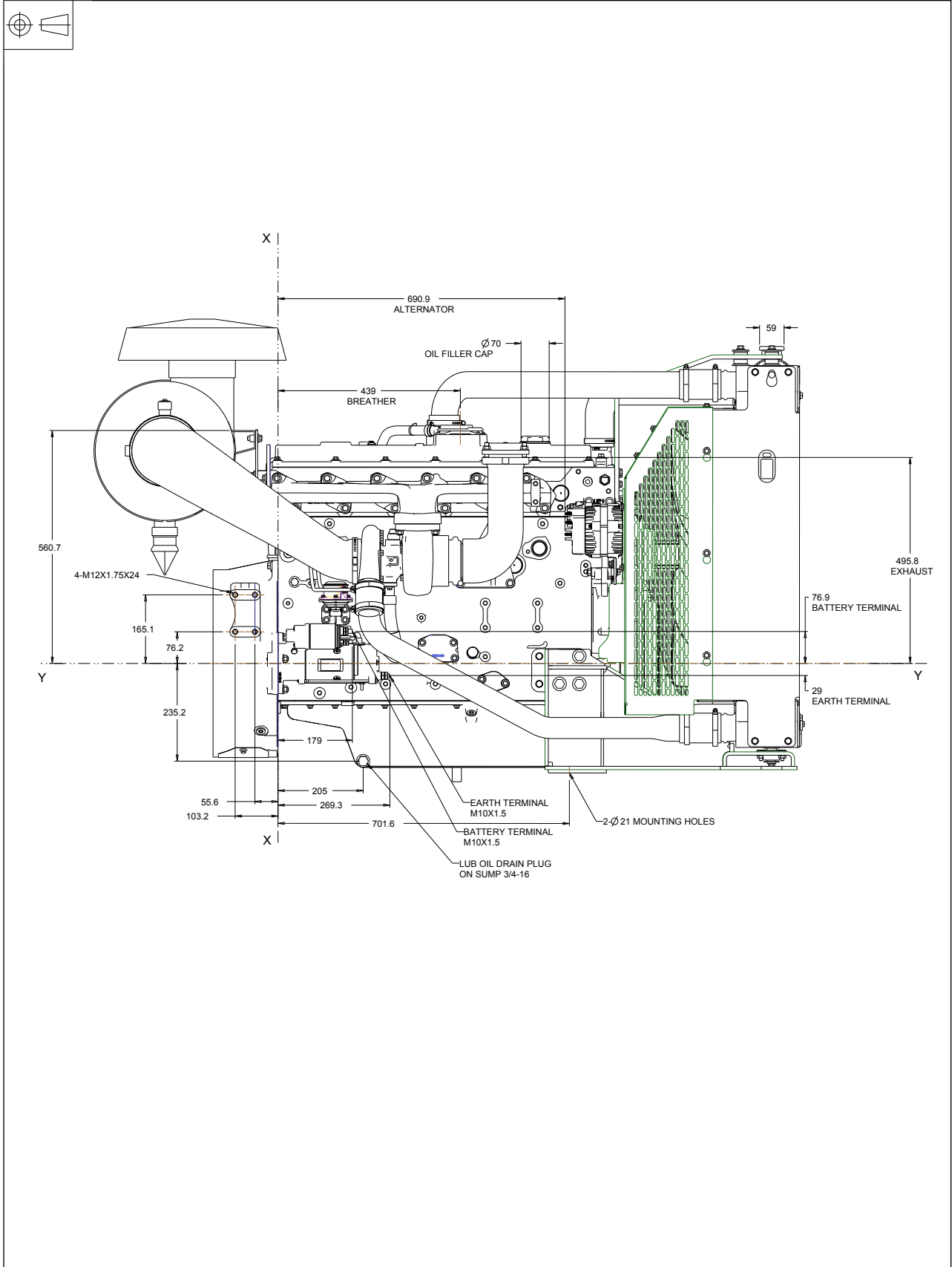



# 1106A-70TAG2 - Rear view

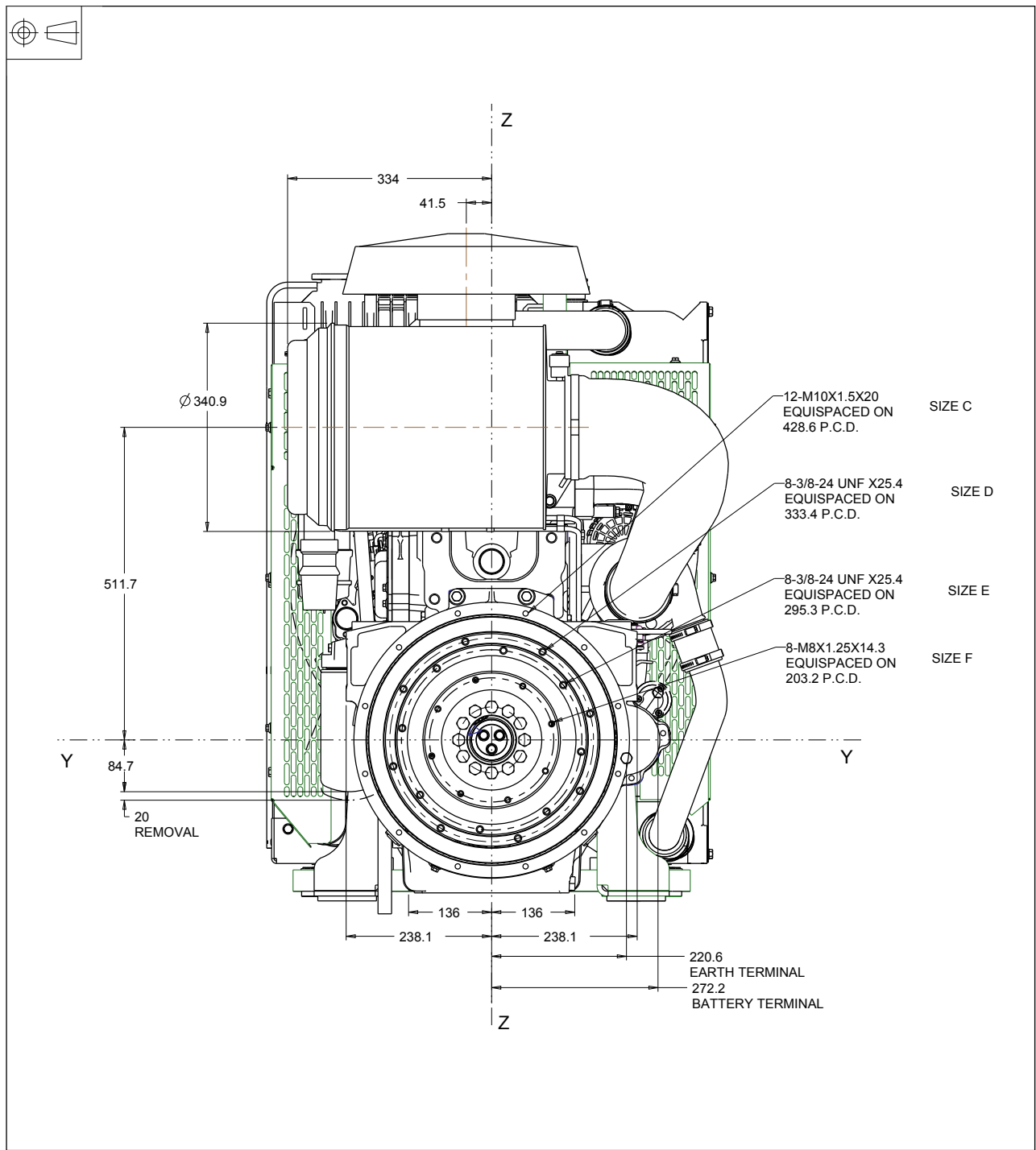

Option	Part	Size C	Size D	Size E	Size F
1	C0001 & D0004	12- M10 x 1.5 x 20 EQUISPACED ON 428.63 P.C.DIA	8- 3/8 - 24 UNF x 25.4 EQUISPACED ON 333.38 P.C.DIA	8- 3/8 - 24 UNF x 25.4 EQUISPACED ON 295.28 P.C.DIA	8- M8 x 1.25 x 14.3 EQUISPACED ON 203.2 P.C.DIA
2	C0074 & D0090	12- M10 x 1.5 x 20 EQUISPACED ON 466.725 P.C.DIA	8- M10 x 1.5 x 25.4 EQUISPACED ON 333.38 P.C.DIA		

# 1106A-70TAG2 - Plan view

